

**TRAFLEX**

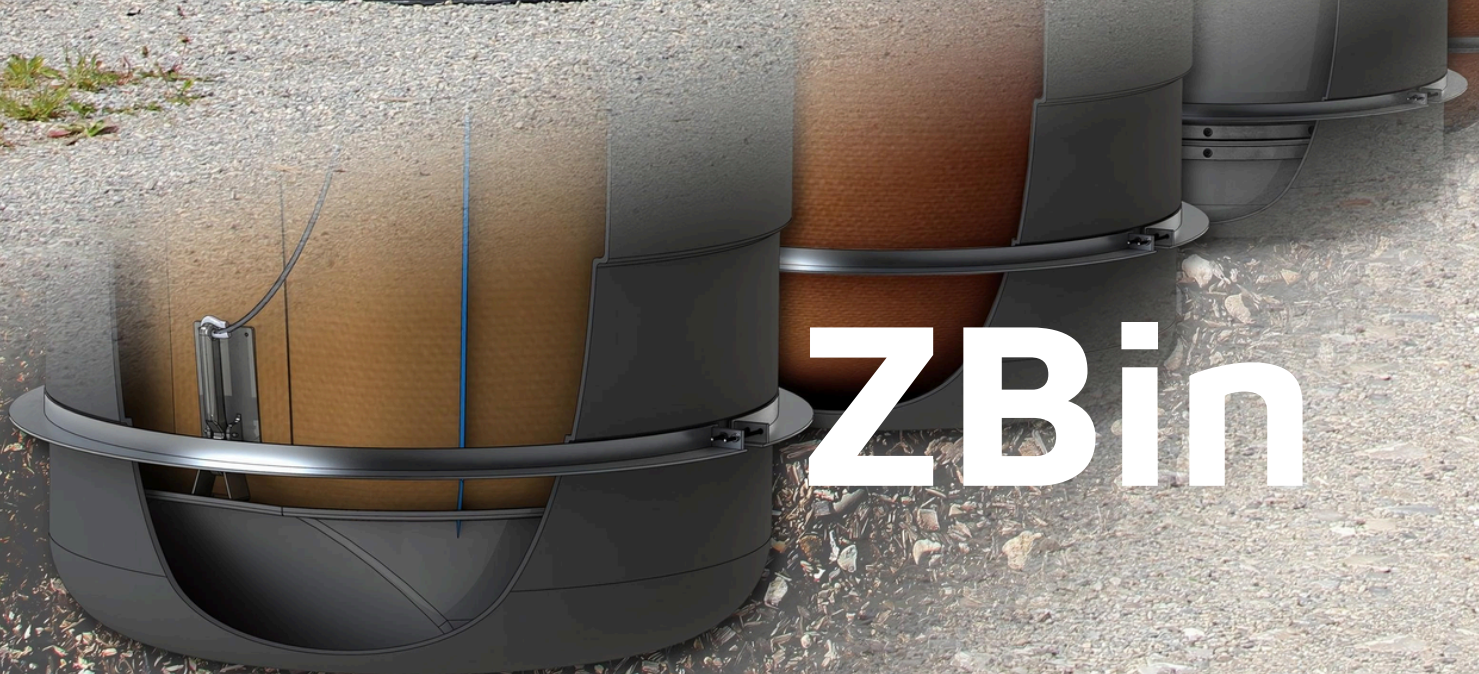

**ZBin**



# About us

Traflux is a globally active **family-owned company**. From our Belgian headquarters in Houthalen-Helchteren, we develop and manufacture (semi-)underground waste containers. Thanks to a unique combination of innovative designs, high-quality materials and advanced technologies, we offer waste solutions ranging from 100 to 5,000 litres for every sector.

From our 8,000 m<sup>2</sup> production facility, equipped with state-of-the-art machinery, we provide **global distribution** to more than 30 countries. In addition, Traflux operates its own collection company in Belgium. Every day, our drivers empty more than 1,200 containers. Their experiences help us continuously improve our products.

Traflux considers reducing **ecological impact** as a priority. We generate more electricity with our solar panels than we consume. Furthermore, we consciously choose sustainable, recycled and environmentally friendly materials. For instance, our containers comply with EN 13071 standards, our lifting bags with ISO 21898 standards and our wood is PEFC certified. We operate in accordance with ISO 9001 and ISO 14001 standards.

At Traflux, everything is centred around these core values:

- T**eamwork
- R**esult
- A**uthenticity
- F**lexibility
- L**oyalty
- U**nique
- X**-Factor

**TRAFLUX**

# Why choose a semi-underground solution?

**TRAFLEX**

## Size does matter

The figure below clearly demonstrates: size does matter. Fewer containers are required, and the time needed to collect and remove waste is reduced. This lowers both investment and collection costs. Large volume, compact design.

## Design & Ergonomics

Design has played a crucial role in shaping the functionality and experience of the ZBin. Every element has been carefully integrated to create a cohesive whole, ensuring that the container is both safe and easy to use.

## Safe

By incorporating a barrier of at least 800mm in height, no large openings are left exposed when the semi-underground containers are emptied, ensuring the safety of operators. Additionally, the use of plastic materials creates softer edges that do not splinter, reducing the risk of cuts

## Quality & Reliability

We use only high-quality materials selected for their durability. Our virgin plastics provide excellent UV stability, while aluminium and stainless steel prevent corrosion. Additionally, our containers are seamless and feature double-walled lids for added strength.

## Environment

All materials used in our ZBin are 100% reusable, free from concrete and galvanized steel. A ZBin weighs 15 times less than a fully underground system, significantly reducing its carbon footprint during transport and installation.

## Efficiency & Comfort

The efficiency of the semi-underground concept lies not only in the ease of emptying the containers but also in the minimal surface area required for installation. Additionally, our inner lid is significantly easier to open compared to alternative solutions.

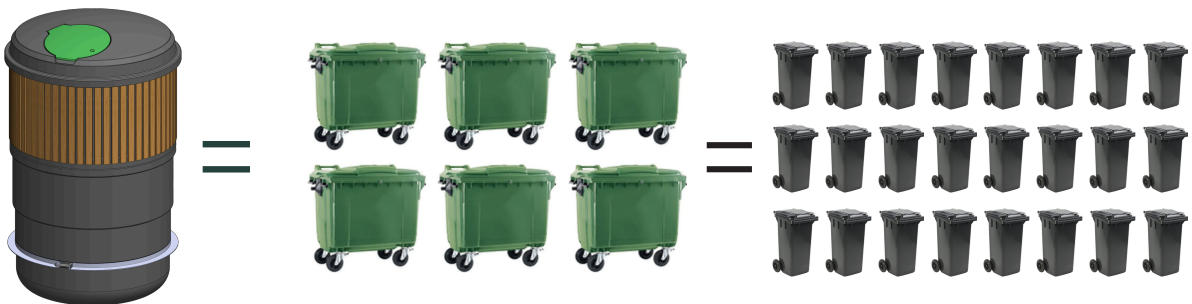

Comparison between 1x ZBin 5000L = 6x 1100L wheelie bins or  
24x 240L wheelie bins

**TRAFLEX**

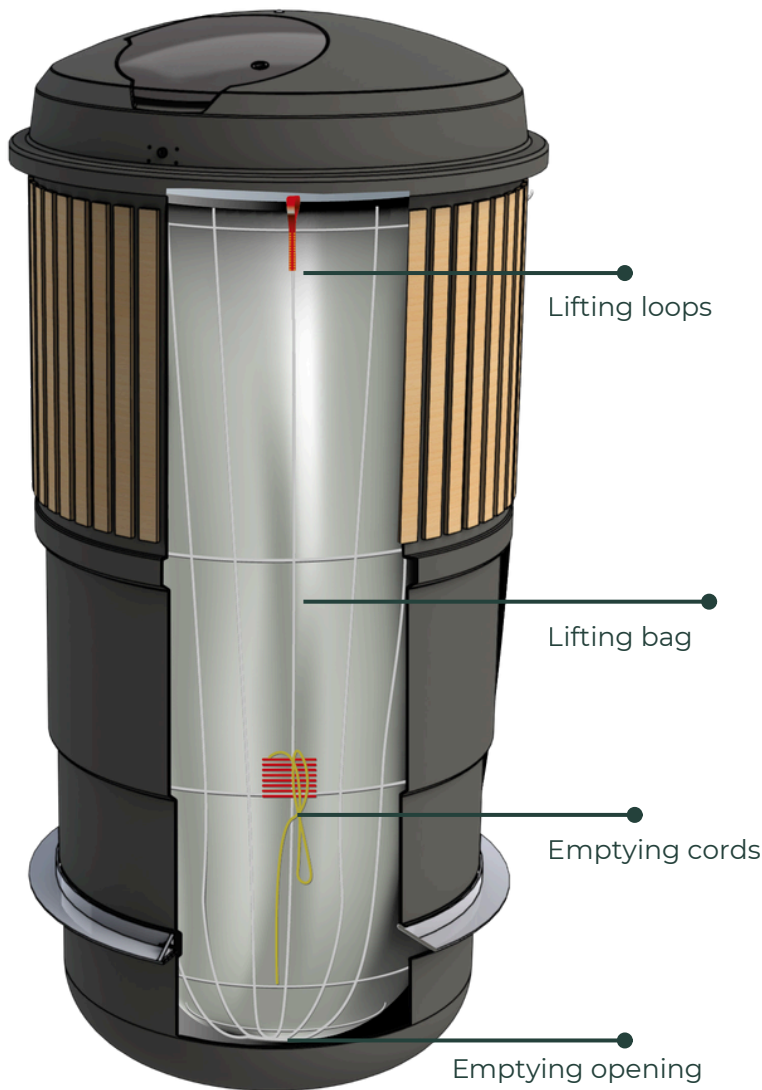

## Quality

Traflux's ZBin is made from the highest-quality materials, with each component designed for maximum durability. The plastic pit is manufactured according to the latest standards and cutting-edge technologies. Additionally, the ZBin is produced using rotational molding, resulting in a seamless and uniformly sturdy construction.

## Emptying

The ZBin is equipped with an internal lifting bag or container, making waste removal effortless. This design ensures the ZBin is suitable for almost any fraction of waste. Depending on its size, the container can be used for paper and cardboard, plastics, glass, biowaste, residual waste, ...

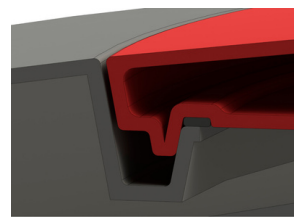

Detail section:  
"odour lock"

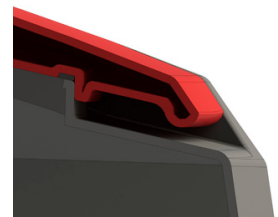

Ergonomic handle  
detail (fully integrated  
into the lid)

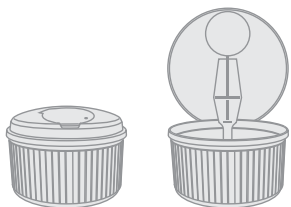

**1.** Open the ZBin; the gas spring ensures that the lid stays open, allowing a smooth and effortless operation.

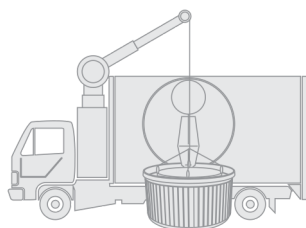

**2.** Secure the inner bag to the crane using the provided loops.

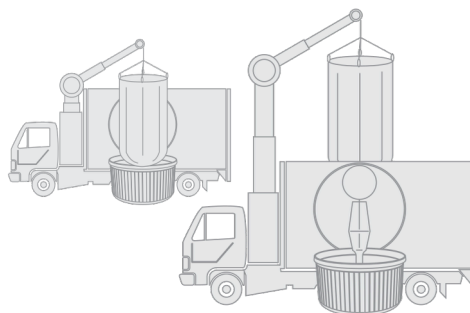

**3.** The inner bag is lifted from the container and emptied into the truck.



**4.** Place the bag into the ZBin and close the lid. The ZBin is now ready for use again.

# ZBin - options and components



## Filling lid color options

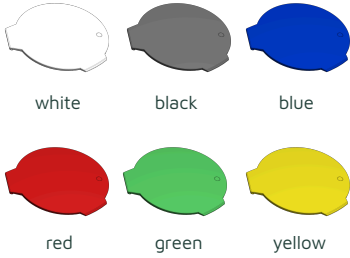

## Opening options



## Locking options

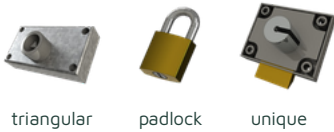

## Framing options

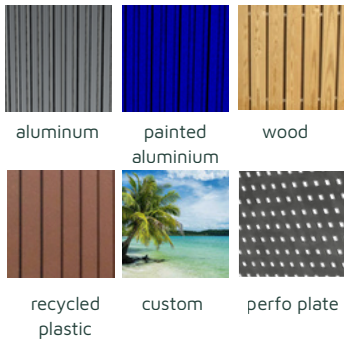

## Lifting options

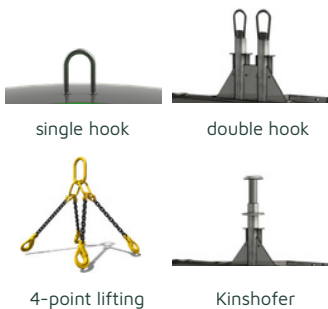

## Detailed view

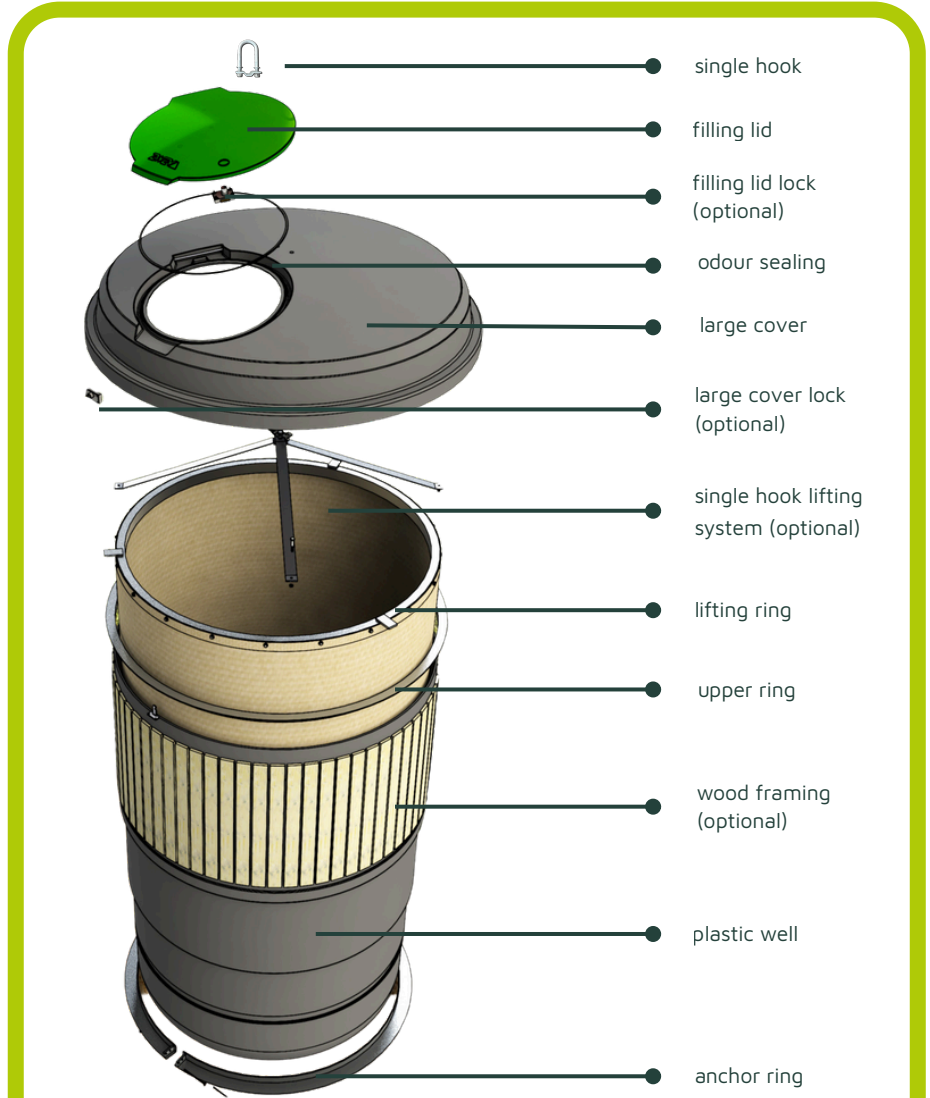

## Lifting bags/containers

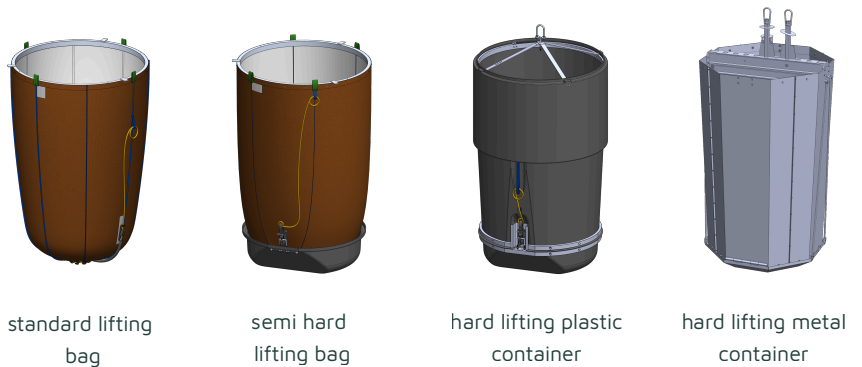

# ZBin - product range

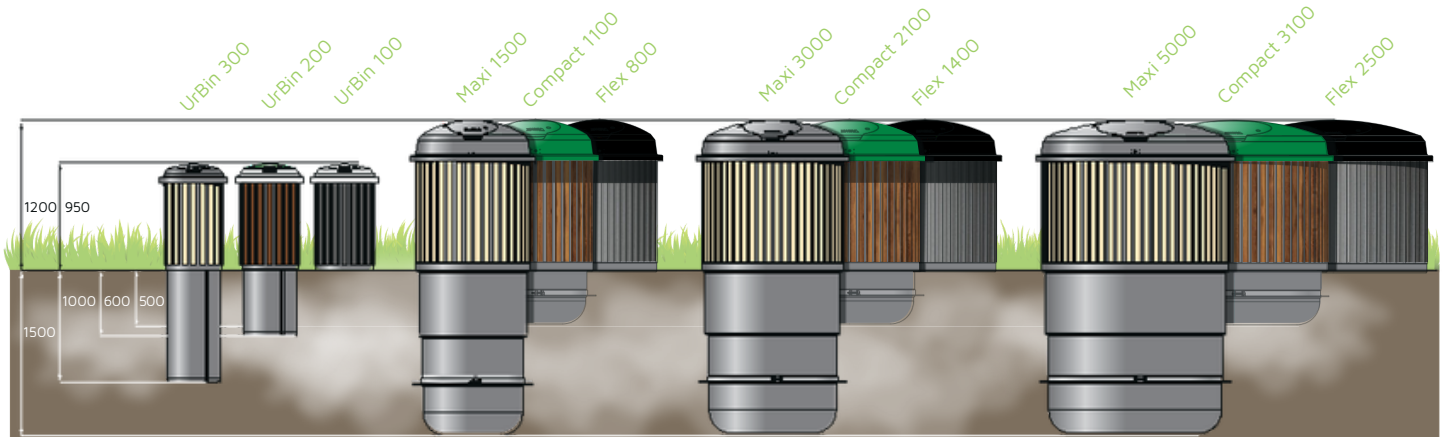

Type	300L	200L	100L	1500L	1100L	800L	3000L	2100L	1400L	5000L	3100L	2500L
Height (mm)	1950	1550	950	2700	1700	1200	2700	1700	1200	2700	1700	1200
Width (mm)	Ø 590			Ø 1100			Ø 1300			Ø 1700		
Weight	35 kg	30 kg	25 kg	90 kg	70 kg	60 kg	130 kg	100 kg	87 kg	195 kg	150 kg	130 kg
Fill volume	0.3m <sup>3</sup>	0.2m <sup>3</sup>	0.1m <sup>3</sup>	1.5m <sup>3</sup>	1.1m <sup>3</sup>	0.8m <sup>3</sup>	3.0m <sup>3</sup>	2.1m <sup>3</sup>	1.4m <sup>3</sup>	5.0m <sup>3</sup>	3.1m <sup>3</sup>	2.5m <sup>3</sup>

## For all fractions

The ZBin semi-underground waste containers are available in volumes ranging from 100L to 5,000L. For waste disposal, lifting bags, semi-hard bags, or hard containers are available. All solutions are tailored to the waste fraction.

## Compact

The ZBin Compact is designed to offer a large volume with a maximum installation depth of just 50cm. In locations where deeper excavation is difficult or restricted, the ZBin Compact is the ideal solution.

## Maxi

The ZBin Maxi is the workhorse of the semi-underground bins. Offering the full benefits of large volume within a limited surface area. This is the ideal choice for efficient waste collection. The installation depth is approximately 1.5 meters.

## Flex

If you need flexibility in your waste storage solutions, the ZBin Flex is the ideal choice. It offers high volume and quick emptying capabilities without requiring permanent installation. The perfect solution for events and festivals of any size, while also offering a flexible approach to seasonal waste collection.



# References

**TRAFUX**



**TRAFUX**

**TRAF**FLUX

# YOUR WASTE OUR PASSION

**TRAF**LUX

Europark 1003, 3530 Houthalen-Helchteren

Belgium

Tel.: +32 11 51 62 70

Mail: [info@traflux.com](mailto:info@traflux.com)

Website: [www.traflux.com](http://www.traflux.com)

